

Soft WaveFold TrackSystem

INSTALLATION INSTRUCTIONS

Step 1. Check Package Contents

Missing part? Call 800-264-1190

Mounting hardware includes the following:

Part	Quantity
a. Aluminum Track	1 (wide tracks will have 2 or more sections)
b. Track Connector/Splice	1 per splice (for multiple sections tracks only)
c. Baton	1 for One-Way draw 2 for Center draw
d. Brackets	4 for tracks up to 86" wide 6 for tracks 86" to 104" wide 8 for tracks 104" to 172" wide 12 for tracks 172" to 240" wide
e. 1½" Screws	3 per bracket for standard wall mount
1¼" Screws	2 per bracket for ceiling mount

Note: Use dry wall anchors (not included) to mount to hollow wall board.

Step 2. Tools Required

Tape Measure, drill, drill bits (3/32" for wall studs or ceiling beams, ¼" for wall anchors), screw driver, pencil, step stool or ladder, spirit level, hammer (to tap in anchors if necessary), pliers



Step 3. Bracket Location and Installation

Read these instructions from start to finish before proceeding. It is a very good idea to recruit a helper when installing the track. Measure the length of your draperies carefully, and then familiarize yourself with the method of attachment to the track system in order to determine the proper height of the brackets.

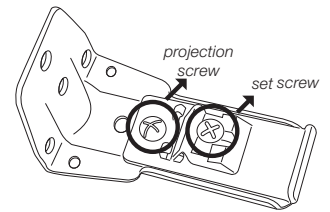
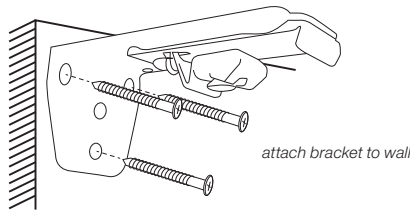
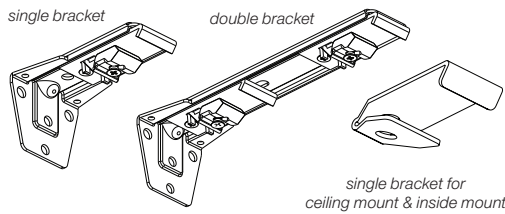

Length/Height: Add 1" for the height of the track. Add an additional 1" for floor clearance for floor length treatments. For window length treatments, predetermine where you want the bottom hem to fall and position the brackets accordingly.

4 Brackets: Place one bracket 3" to 4" from each end of the track; and place a bracket 4" to 6" to the left of the center of the track, and a bracket 4" to 6" to the right of center.

6 to 12 Brackets: Position (4) brackets as described above and then evenly space one, two or three brackets between the end bracket and the center bracket on the left side of the track, and repeat on the right side of the track. You will have a total of 6, 8 or 12 brackets based on the width of the track.

The Brackets must be level and perfectly aligned! You can make pencil marks on the top of the track sections to correspond with the bracket positions, and then utilize the level while using the track as a straight-edge to achieve perfect alignment by making pencil marks on the wall or window frame at the bracket locations.

Position the brackets and make pencil marks for the screw locations. It is recommended that the screws be driven directly into a wall stud – deviate from the recommended bracket spacing based on the location of the wall studs.

If it is not possible or practical to mount to wall studs, use dry wall anchors (not included).

Drill starter holes for the screws or screws and anchors. Attach each bracket using the 1¼" screws.

Step 4. Securing the Track

Some tracks will come in multiple sections. Slide the Connector onto the track as illustrated. Tighten the screws with a Hex Wrench (included with the connector for standard mounts, does not apply for ceiling mounts) - make sure the Connector is securely attached to both track sections. This assists in alignment when attaching the track to the brackets, and maintains rigidity at the splice after installation. For Ceiling Mounts slide the track of the connecting ends on each track into the channel of the splice and butt ends together. The tracks will snap together. Press together and confirm a tight fit.

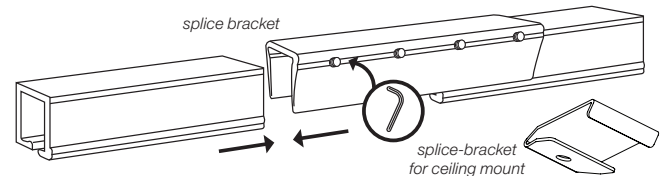

Snap the track into the brackets as shown. Place the top-front of the track into the hook at the front of the bracket, and then press the back of the track upward until the plastic retainer snaps onto the back of the track, and then tighten the set screw on each bracket.

Adjust the track to the desired projection. Projection is adjustable from 3" – 4 ½".

Repeat this step for the remaining brackets.

Once desired projection is set for all the brackets, lock each bracket into position by tightening the track depth adjustment set screw.

For Double Brackets, attach the rear track first. For ceiling mounted double treatments, the brackets for the rear track must be at least 2" from the wall, and the brackets for the front track must be ¾" to 1½" from the rear brackets.

Make sure each bracket is properly attached to the track before proceeding.

To remove the track, loosen each set screw; and then simultaneously push back and pull the back of the track downward.

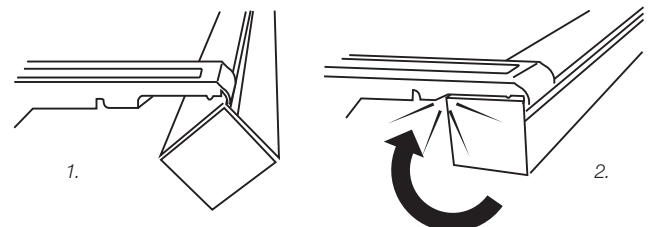

Step 5. Attach the Baton(s)

For center-draw, put one Baton on the slider-connector between the 1st and 2nd Snap Carriers of the left panel and one Baton in the same position on the right panel. For one-way-draw, put the Baton on the slider-connector on the end that will control the movement of the panel.

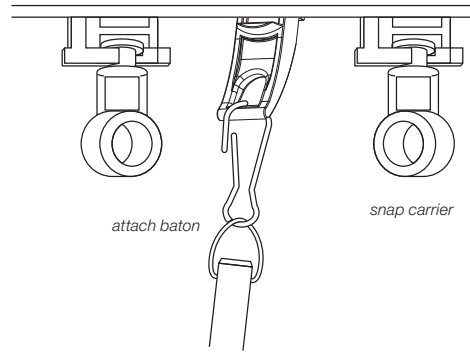
Step 6. Attach the Panel(s)

The drawings show the proper attachment of the panel heading to the carriers in the track. Snap Carriers are pre-attached to the panel(s) with the exception of the last snap at the fixed end of each panel, which must be attached to the pre-installed snap carrier at the end of the track. The use of pliers is recommended as the snap fits very tightly into the snap carrier – wrap tape around the jaws of the pliers to prevent damage to the fabric. Sequentially attach a Snap Carrier to each Carrier in the track.

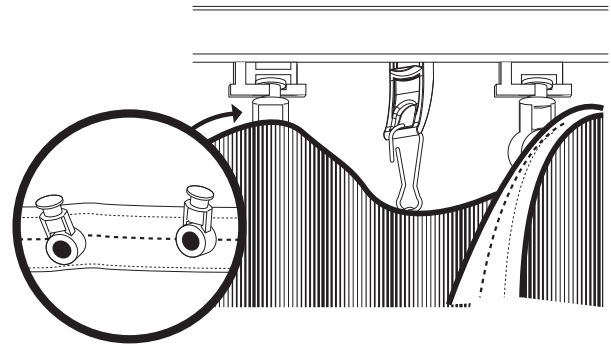
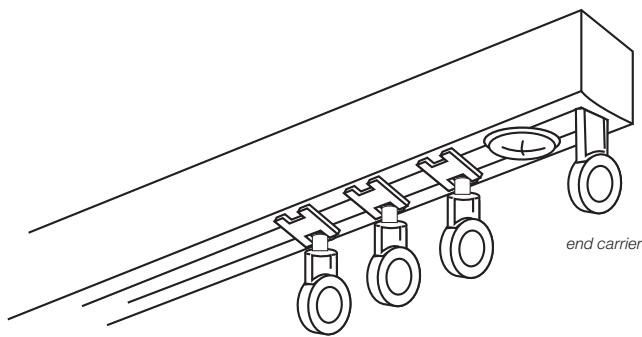
**How to Operate**

Note that the wand is positioned inside the first fold at the draw end of each panel. To traverse the panel(s), reach inside the first fold in order to grasp the Baton and then pull or push slowly to move the panel.

WHAT TO EXPECT WHEN YOU RECEIVE YOUR SOFT WINDOW TREATMENTS

The packaging and shipping of soft treatments frequently results in minor wrinkling of the fabrics used.

There are different characteristics and handling needs for the variety of fabrics offered in this program.

Please refer to the descriptions below for guidance on how to remedy minor wrinkles upon delivery.

First, allow all items to hang for a few days so wrinkles relax and begin to fall out.

Silk fabrics

- Silk has natural irregularities that give the fabric its unique and desired character. The appearance of slubs, nubs, loops and barre ridges are universally accepted as normal and should not be considered defects.
- Silk should be lined with Thermal Sateen or Blockout lining to avoid color fading.
- If necessary, steam silk to remove stubborn wrinkles. Please note that a good quality steamer is needed so water spots won't form from water spitting out from the steaming device.

Rayon/Poly blends

- If necessary, steam rayon/poly blends to remove stubborn wrinkles. Please note that a good quality steamer is needed so water spots won't form from water spitting out from the steaming device.

100% Polyester

- If necessary, steam polyester or gently iron on a low heat setting to remove stubborn wrinkles. 100% Polyester fabrics will release wrinkles easily by steaming or ironing on the Polyester / Synthetic Fabrics setting (Low), but may melt if the iron is too hot.

Cotton/Poly blends

- If necessary, gently iron on a Blended Fabric (Medium) heat setting to remove stubborn wrinkles.

100% COTTON and 100% LINEN

- If necessary, gently iron on a Cotton (High) heat setting to remove stubborn wrinkles.

General Cleaning Guidance:

- Dry Cleaning is the best method to clean soiled soft window treatments.
- However on 100% Polyester, Cotton/Poly blends, 100% Cotton and 100% Linen you may: Spot clean with warm soapy water using mild detergent and a clean sponge. Air dry, and then steam or iron as guided above.