

**Cordless**  

---

**Banded**Fabric  

---

Loop**Roller**Shade  
owner's handbook

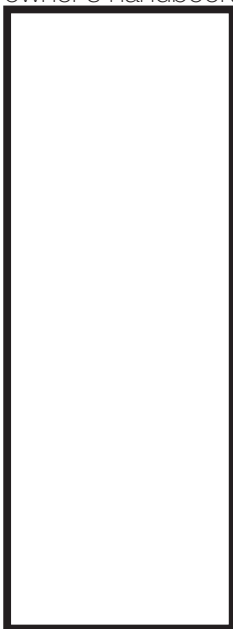



## INSTALLATION INSTRUCTIONS

### Step 1. Check Package Contents

Missing part? Call 800-264-1190

Mounting hardware kit includes the following:

Part	Quantity
a. Mounting Brackets	2 for shades up to 45" wide 3 for shades up to 72" wide
b. Extension Brackets (for outside mounts)	2 for shades up to 45" wide 3 for shades up to 72" wide
c. Screws	4 for shades up to 45" wide 6 for shades up to 72" wide
d. Wall Anchors	4 for shades up to 45" wide 6 for shades up to 72" wide
e. Handle for Bottom Rail	1 for shades up to 48" wide 2 for shades over 48" wide

### Step 2. Tools required

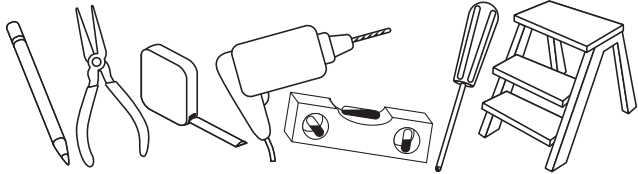

Pencil, tape measure, level, screw driver, pliers, step stool, drill.

### Step 3. Installation

Your blind may be installed either inside the window frame or outside the window frame.

**Wallboard or Plaster:** use wall anchors.

**Concrete, Stone, Brick:** use a masonry drill bit and anchors or screws specifically designed for masonry (not included).

#### Inside Mounting:

One bracket should be positioned about 2" to 6" from each end of the head rail. For wider shades that require 3 or 4 brackets, these should be spaced evenly between the two outermost brackets.

Attach each bracket to the inner top of the window opening using the screws provided. Pre-drill the screw holes using a 5/64" drill bit. The extension brackets are not used for inside mounts.

For flush inside mounts, attach the brackets to the head rail first (see drawings and attachment instructions below), and then position the shade in the window opening as desired. Then make pencil marks at the back of each bracket. Remove the brackets by pressing on the plastic tab. Align the brackets with the pencil marks, and then screw them in place as described above.

#### Outside Mounting:

Attach the Extension Brackets to the wall or window framing. One bracket should be positioned about 2" to 6" from each end of the head rail. For wider shades that require 3 or 4 brackets, these should be spaced evenly between the two outermost brackets. Pre-drill the screw holes using a 5/64" drill bit.

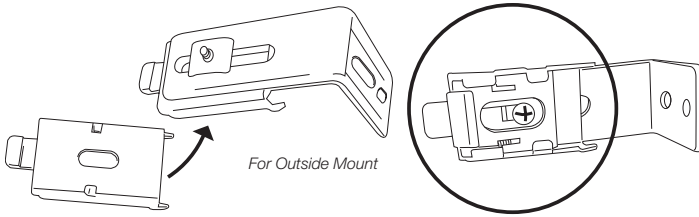

The brackets must be level – use a Spirit Level if necessary to assure proper alignment.

Then attach a Mounting Bracket to each Extension Bracket using the nut and bolt pre-attached to each Extension Bracket.

To adjust head rail extension, remove the shade from the mounting brackets by pressing on the plastic tabs at the front of each bracket. Then loosen the nut and bolt, and move the mounting brackets forward or backward as preferred.

#### Step 4. Securing the Head Rail

Slide the inner rear of the head rail onto the metal tabs at the back of each bracket, and then push up so that the brackets snap onto the head rail.

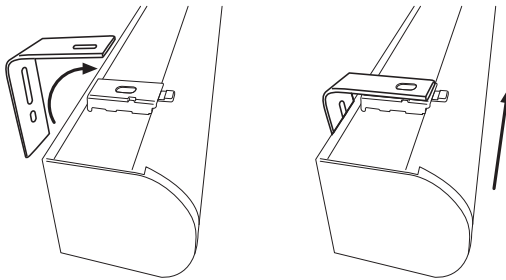

#### IMPORTANT FINAL STEP TO PROPERLY SECURE BRACKETS:

pull the plastic tab on the front of each bracket outward toward the front of the shade to lock the brackets in place. For inside-mounts use pliers to grasp the tabs. Check carefully to assure that each bracket is properly secured

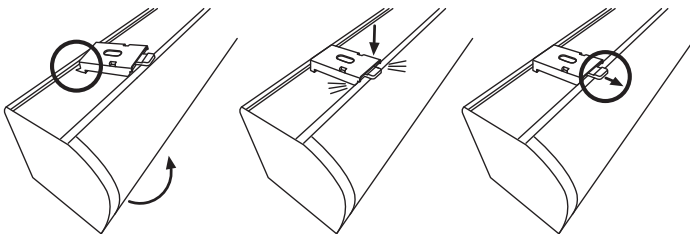

#### Step 5. Attach Handle

Attach the clear plastic Handle to the center of the bottom rail as illustrated.

Wider shades have (2) Handles – to precisely determine the correct position for each handle, divide the total width of the shade by 4, and then attach one handle that distance from each outside edge

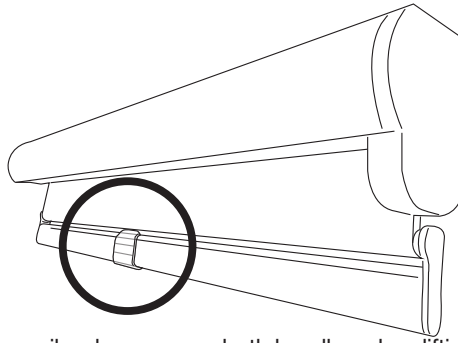

of the bottom rail – always grasp both handles when lifting and lowering the shade.

#### Step 6. How to Operate

**IMPORTANT**  
**Operating & Care Instructions for Cordless Shades**  
**READ CAREFULLY**

- To maintain optimal performance of the springs that make your cordless shade function, lift and lower your shade through its full range of motion – all the way up and down – frequently.

**GO SLOW!**  
**Be sure the bottom rail handles are properly positioned as described above (step 5) - lift or lower the shade slowly and evenly, keeping the rail level, until the shade is positioned as desired.**  
**IMPROPER OPERATION CAN DAMAGE THE SHADE.**

- If you have trouble lifting your cordless shade:  
If the shade is left in one position for a long period of time, it might be necessary to lift and lower the shade several times to restore normal function.  
If the shade has been fully raised for a long period of time, it might tend to spring-back (rebound) slightly from the desired length position. This can also be remedied by lifting and lowering the shade several times.

#### CLEANING

To clean the shade fabric, use a feather duster or vacuum lightly using the soft brush or upholstery attachment. For spot cleaning, use

warm (not hot!) water with a mild soap to damp clean.

#### REPLACEMENT PARTS

In the event that replacement parts are ever needed, you may call: 1-800-264-1190

Please be sure to provide the following information, if possible:

- The complete model or catalog number of your product
- A description of the product
- A description of the part needed

## LIMITED LIFETIME WARRANTY

The enclosed product is warranted to the original residential retail purchaser as long as the product remains in the original window.

### **Covered:**

**Lifetime:** Entire product against manufacturing defects (i.e. a flaw in the product design, materials, or workmanship that causes the product to no longer function)

**3 years:** Cords including internal cords such as those found in cordless blinds. **5 years:** All fabric

### **Not Covered:**

Normal Wear and Tear

**Any product that fails due to:** abuse • exposure to salt air • improper installation • accident • extraordinary use • improper operation • alterations • improper cleaning • misapplication • damage from pests/insects/pets • improper handling • misuse.

**Natural wood products that have:** loss of color intensity • yellowing or cracking of plastic parts or foam wood product • variations in color, grain, or texture • warping of wood slats in high humidity areas.

**Costs associated with:** product removal • transportation to and from the retailer • brand label removal • product remeasure • incidental or consequential damages • product reinstallation • shipping.

In the event there are multiple blinds/shades in the same room, only the defective blind/shade will be replaced.

### **To Report Shipping Damage:**

If damage occurred during shipping, call place of purchase and report within 7 calendar days or else you may be denied credit for your damaged product.

### **To Obtain Service:**

If you suspect this product has a manufacturing defect in materials or workmanship:

1. Locate the sales receipt
2. Call place of purchase

Any unauthorized returns will not be accepted.

### **Warranty Remedy:**

**THIS SHALL BE YOUR SOLE REMEDY UNDER THIS LIMITED WARRANTY.**

If this product is found to have a manufacturing defect in materials or workmanship, we will (at our discretion) do one of the following

- repair the product
- replace the product
- refund the cost of the product

Colors vary from lot to lot and may not exactly match sample swatch or previous purchases. Discontinued items or color selections will be replaced with the closest equivalent current product.

### **YOUR RIGHTS UNDER STATE LAW:**

This lifetime limited warranty gives you specific legal rights, and you may have other rights, which vary from state to state. Some states do not allow limitations on how long a warranty lasts, so the above limitations may not apply to you.

No agent, representative, dealer, or unauthorized employee has the authority to increase or alter the obligation of this warranty. This lifetime limited warranty supersedes any previous versions.