

# Installation Instructions for Roller Shade with Continuous Chain Operation

Part No. MEIN0217 Rev. 2 **ENG**

## Tools Required:

Tape measure, pencil, drill, drill bits, screw driver, scissors, step stool.

Note: use a 5/64" drill bit to pre-drill the screw holes (for attachment to a wall stud or header board). Use a 1/4" drill bit for plastic anchors (for hollow dry wall or plaster mounting).

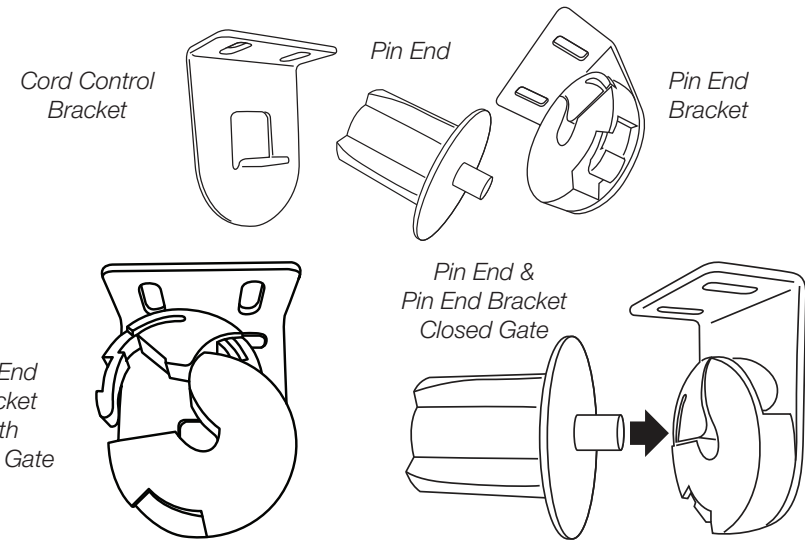
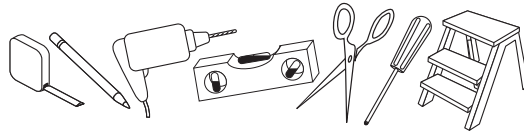

<b>⚠ WARNING</b>	<b>⚠ ADVERTENCIA</b>
<p>Window Blind Cord Can <b>STRANGLE</b> Your Child</p> <ul style="list-style-type: none"> <li>Children can climb furniture to reach cords.</li> <li>Move crib and furniture away.</li> <li>Keep all cords out of children's reach.</li> <li>Attach tension device to wall or floor.</li> <li>Fasteners provided with tension device may not be appropriate for all mounting surfaces.</li> <li>Use appropriate anchors for the mounting surface conditions.</li> </ul>	<p>La cuerda ciega del a ventana puede <b>ESTRANGULAR</b> su niño</p> <ul style="list-style-type: none"> <li>Los niños pueden subir los muebles para alcanzar las cuerdas.</li> <li>Mueva la cuna y los muebles.</li> <li>mantenga todas las cuerdas fuera del alcance de los niños.</li> <li>Conecte el dispositivo de tensión a la pared o suelo.</li> <li>Los sujetadores provistos con el dispositivo de tensión pueden no ser apropiados para todas las superficies de montaje.</li> <li>Utilice anclajes apropiados para las condiciones de la superficie de montaje.</li> </ul>

the shade to slide into the bracket (see illustration).

Mark the screw locations with a pencil – pre-drill the screw holes using a 5/64" drill bit. If mounting to hollow drywall, use the wall anchors provided – pre-drill the holes with a 1/4" drill bit.

### Step 2. Mounting the Shade

Important – do not remove the Twist-Tie from the Cord Control & Chain until the shade has been attached to the brackets.

Push the cord control mechanism onto the bracket post such that the cord hangs straight down.

Open the gate on the pin end bracket by pushing on the tab (see illustration). Slide the pin end of the shade into the bracket such that it rests in the center recess. Close the gate making sure that it snaps shut.

### Step 3. Attach the Tension Device

The Tension Device must be attached per these instructions in order for your shade to function properly. Carefully unwrap the control cord/chain and tension device. Cut and remove the zip-tie.

While holding the tension device in one hand, pull the plunger away from the bead chain with the other hand. Lift the bead chain out of the bead locking groove and slide the tension device to the bottom

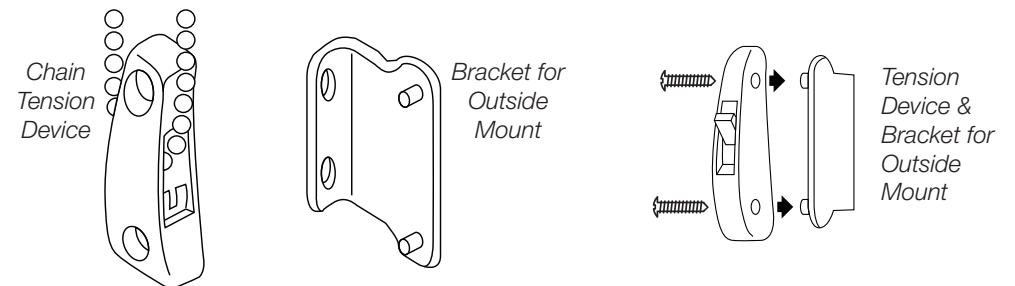

### Step 1. Mount the Brackets

Attach the brackets to the window frame, molding or ceiling. For Inside Mount, the base of each bracket must face upward (the brackets cannot be side mounted). The bracket for the cord control end of the shade has a post that fits into the end of the cord mechanism (see illustration).

The other bracket is for the pin end of the shade. This bracket has a locking gate that opens to allow the pin end of

# Installation Instructions for Roller Shade with Continuous Chain Operation

of the chain loop. Pull the tension device down until the bead chain is fully tensioned (plunger will be at the top) and then move the tension device up approximately 1/8". Mark the screw locations on the wall or window frame with a pencil.

**Inside Mount:** If mounting into wood, predrill screw holes and then install the tension device using the 1" Phillips head screws provided.

If not securing into wood, use appropriate anchors for the substrate and follow the anchor manufacturer's instructions.

**Outside Mount:** Align the mounting bracket screw holes with the pencil marks. If mounting into wood, predrill screw holes and then install the mounting bracket using the 1" Phillips head screws provided.

If not securing into wood, use appropriate anchors for the substrate and follow manufacturer's instructions.

Press the tension device onto the mounting bracket posts. Carefully install the 3/8" Phillips head screws provided, through the tension device into the mounting bracket using a Phillips head screwdriver.

## DO NOT OVER-TIGHTEN!

### Step 4. Operating the Shade

Pulling the cord smoothly and slowly in one direction raises the shade; pulling it in the other direction lowers it. On shades where the fabric rolls against the window, the front cord lifts the shade.

On shades where the fabric rolls toward the room, the rear cord lifts the shade.

### Cleaning the Shades

Vacuum using the soft brush attachment.

### REPLACEMENT PARTS

In the event that replacement parts are ever needed, you may call: 1-800-264-1190 Please be sure to provide the following information, if possible:

- The complete model or catalog number of your product
- A description of the product
- A description of the part needed.

### LIMITED LIFETIME WARRANTY

The enclosed product is warranted to the original residential retail purchaser as long as the product remains in the original window.

#### Covered

**Lifetime:** Entire product against manufacturing defects (i.e. a flaw in the product design, materials, or workmanship that causes the product to no longer function).

**3 Years:** Cords, including internal cords such as those found in cordless blinds or shades.

**5 Years:** All fabric

#### Not Covered

1. Normal wear and Tear
2. Any product that fails due to:
  - Abuse
  - Alterations
  - Exposure to salt air
  - Improper cleaning

- Improper installation
- Misapplication
- Accident
- Damage from pests/insects/pets
- Extraordinary use
- Improper handling
- Improper operation
- Misuse

#### 3. Natural Wood Products that have:

- Loss of color intensity
- Variations in color, grain or texture
- Warping of wood slats in high humidity areas

#### 4. Costs associated with:

- Product removal
- Transportation to and from the retailer
- Brand label removal
- Product re-measure
- Product reinstallation
- Shipping
- Incidental or consequential damages

In the event there are multiple blinds/shades in the same room, only the defective blind/shade will be replaced

#### To Report Shipping Damage:

If damage occurred during shipping, call the place of purchase and report within 7 calendar days, or you may be denied credit for your damaged product.

#### To Obtain Service:

If you suspect this product has a manufacturing defect in materials or workmanship:

- Locate the sales receipt
- Call place of purchase

Any unauthorized returns will not be accepted.

#### Warranty Remedy:

This shall be your sole remedy under this limited warranty.

If this product is found to have a manufacturing defect in materials or workmanship, we will, at our discretion, do one of the following:

- Repair the product
- Replace the product
- Refund the cost of the product

Colors may vary from lot to lot and may not exactly match sample swatches or previous purchases.

Discontinued items or color selections will be replaced with the closest equivalent current product.

**Your rights under state law:** This lifetime limited warranty gives you specific legal rights, and you may have other rights which vary from state to state. Some states do not allow limitations on how long a warranty lasts, so the above limitations may not apply to you. No agent, representative, dealer or unauthorized employee has the authority to increase or alter the obligation of this warranty. This lifetime limited warranty supersedes any previous versions.